



**ump** technika  
bac



**bac**<sup>®</sup>  
Baltic American Concord



**usg** - Lumbermill of furniture wood blanks



**amg** - The 2<sup>nd</sup> largest pin & dowel manufacturer worldwide



**ump** - Manufacturer of wood furniture elements

**ump** **technika** - Engineering and manufacturing of waste repurposing machinery

**420**

employees

**65 000m<sup>3</sup>**

of timber every year

**25M**

annual turnover



technika



Solutions offered by **UMP Technika** provides companies the ability to repurpose their manufacturing byproducts into valuable solutions such as trade-ready briquettes, heating of facilities, or shredding and compacting of unwanted waste.

**34**

professionals

**>2 100 000 000**

briquettes every year

**3.8M**

turnover

# ABOUT THE COMPANY

---

UAB “**UMP Technika**”, also known as “UMPT”, is one of the subsidiaries of the BAC (Baltic-American-Concord) Group.

Located in Ukmergė, Lithuania, UMPT employs over 35 engineers, machinists and other professionals of the field. The manufacturing plant houses all the necessary equipment to create off the shelf biomass machinery as well as various other custom projects.

Even though we are best known for our flagship product – the BP-500A briquette press, which has its reputation for operating under the harshest of conditions for decades while offering best value in class, that does not end there. Our manufacturing line-up has expanded with shredders, hammer mills and automated briquette packing systems.

The company offers and products and services worldwide – starting from other subsidiaries of BAC to our clients in USA and Vietnam.

R&D department is responsible for creating and implementing custom projects provided by our customers such as furniture assembly machinery, coal crushing plants, and turn-key biomass plants turning scrap waste of the furniture industry into ecological and economical profit-generating briquettes.

---

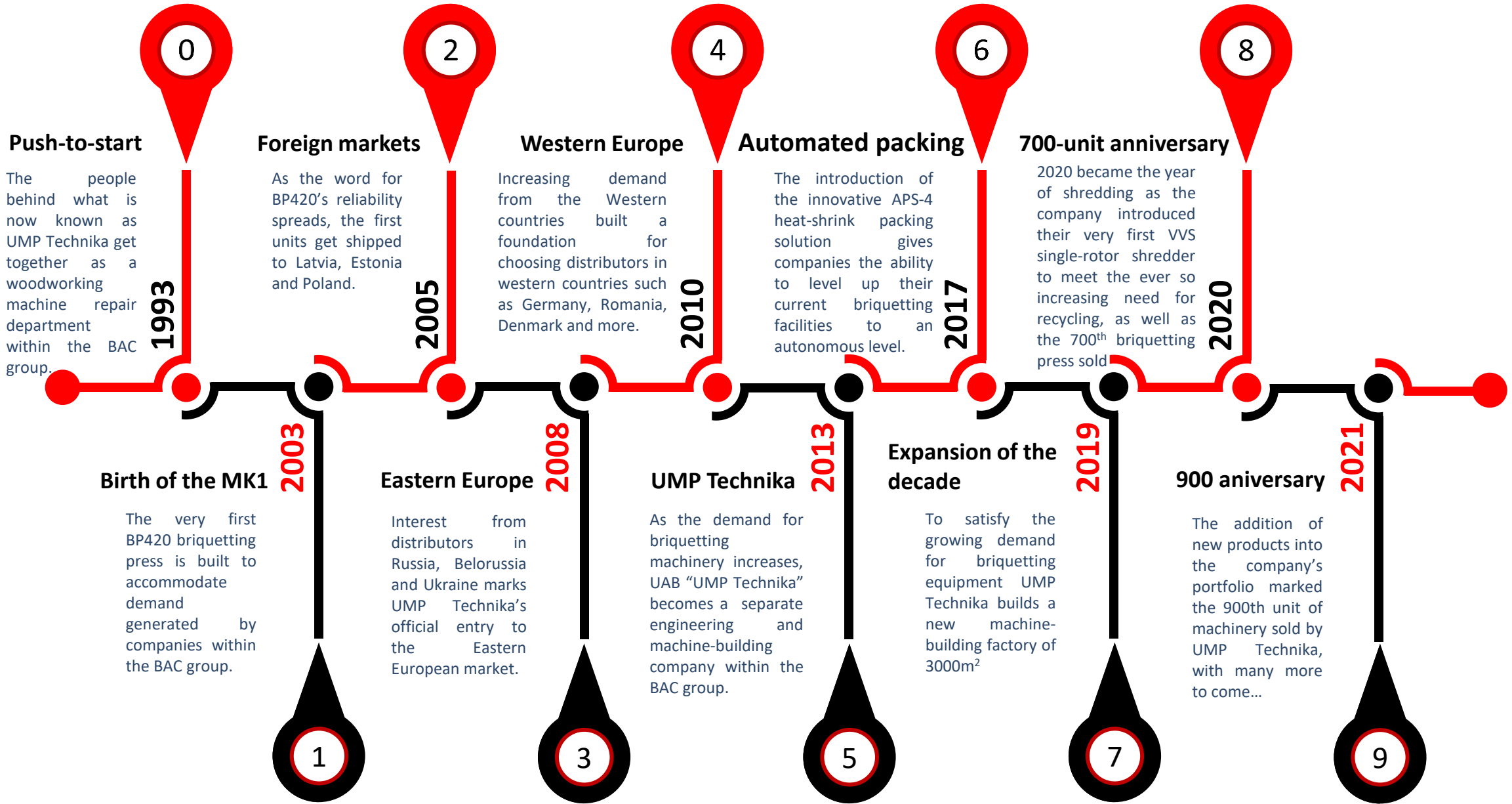

# BRIQUETTING PRESSES SOLD

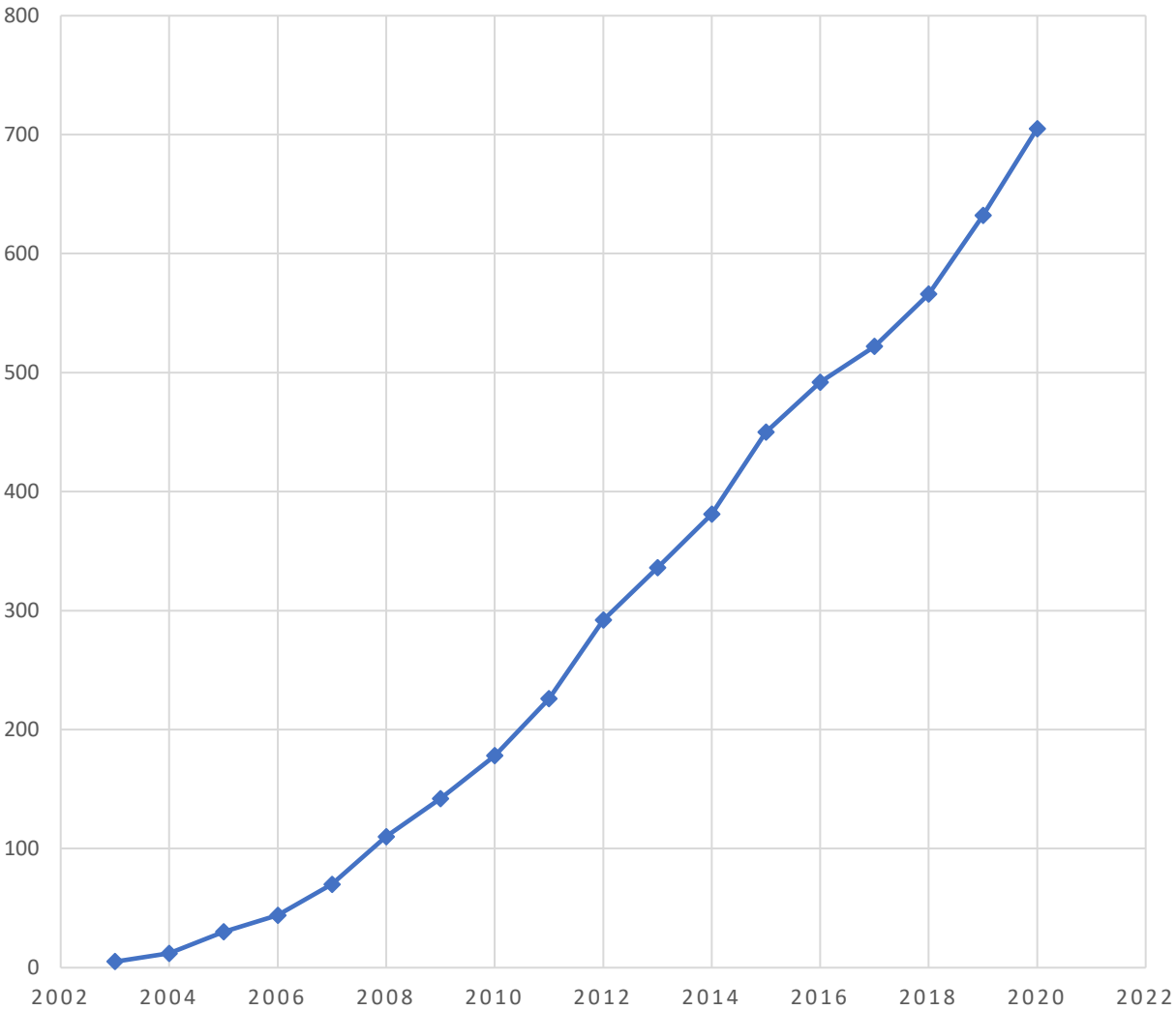

Fig. 2: Accumulated briquetting presses sold over time



***UMP***

technika



**Off-the-shelf**

**Products**

# PRODUCT LINEUP

## Step 1. Shredding



## Step 2. Briquetting



## Step 3. Packing



# VVS 600/800 **Single-shaft shredders**

---



- Shredding capability of up to 3.5m<sup>3</sup>/h
- Gimbal-mounted horizontal hydraulic ram
- Ladder frame chassis
- Enclosed design

## **Drivetrain:**

- Quadruple overload protection
- Heat & dust resistant rotor bearings

## **Monolithic rotor:**

- Replaceable rotor side shafts
- Replaceable blades and blade holders
- 4-sided blades
- Adjustable, single-split counter-blades<sub>9</sub>

<https://www.youtube.com/watch?v=asn5ndzU1GA>

<https://www.briquette.lt/en/produktai/vvs-600-single-shaft-shredder/>

# MM 1500/2000 Hammer mills

---



## Drivetrain:

- Resettable safety coupling
- Load limiter

## Rotor:

- Inspection holes
- Replaceable sieves
- Toolless service hatches
- Free-spinning, replaceable blades
- Outboard bearings

<https://www.briquette.lt/en/produktai/hammer-mill/>

# BP 500/600 Hydraulic briquette presses



- Abrasion resistant internals
- Automated dosing system
- Administered by Siemens HMI controller
- Assured & proven dependability
- Adjustable briquette weight and size
- Adjustable size of internal bunker

<https://www.briquette.lt/en/produktai/hydraulic-briquette-press-600/>

# **NEW PRODUCTS FOR 2021**

---

## **Shredding:**

- Twin-shaft shredders

## **Briquetting:**

- Metal briquetting presses with coolant regeneration

## **Packing:**

- Semi-automatic heat-shrink packing machines

***UMP***

 bac

**technika**

**Custom**

**Solutions**

# K.U.S. Container unloading system

- Purpose built to turn shipping containers into bulk material silos
- Modular design
- Increased surface area of collection

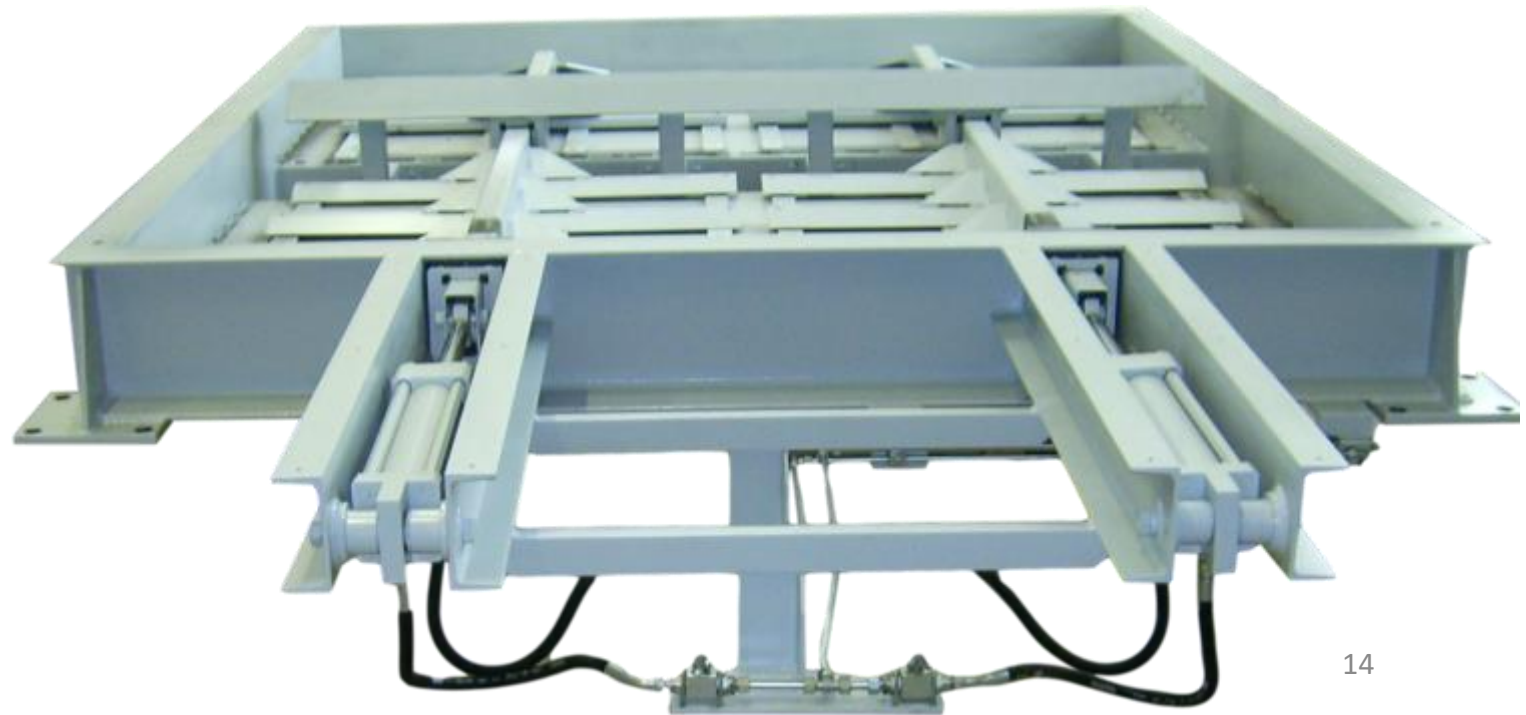
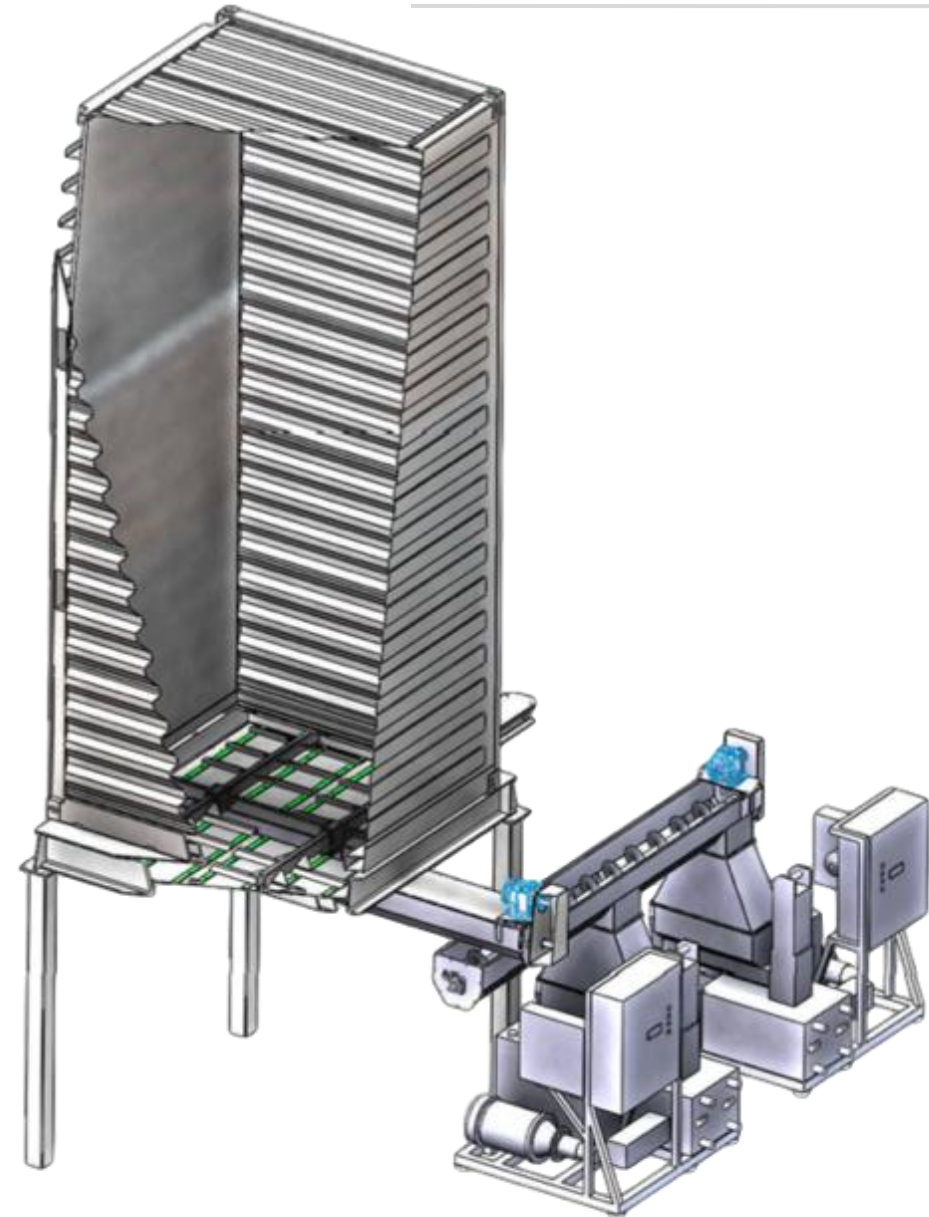

# APS-4 Automated weighting, packing & palletizing system

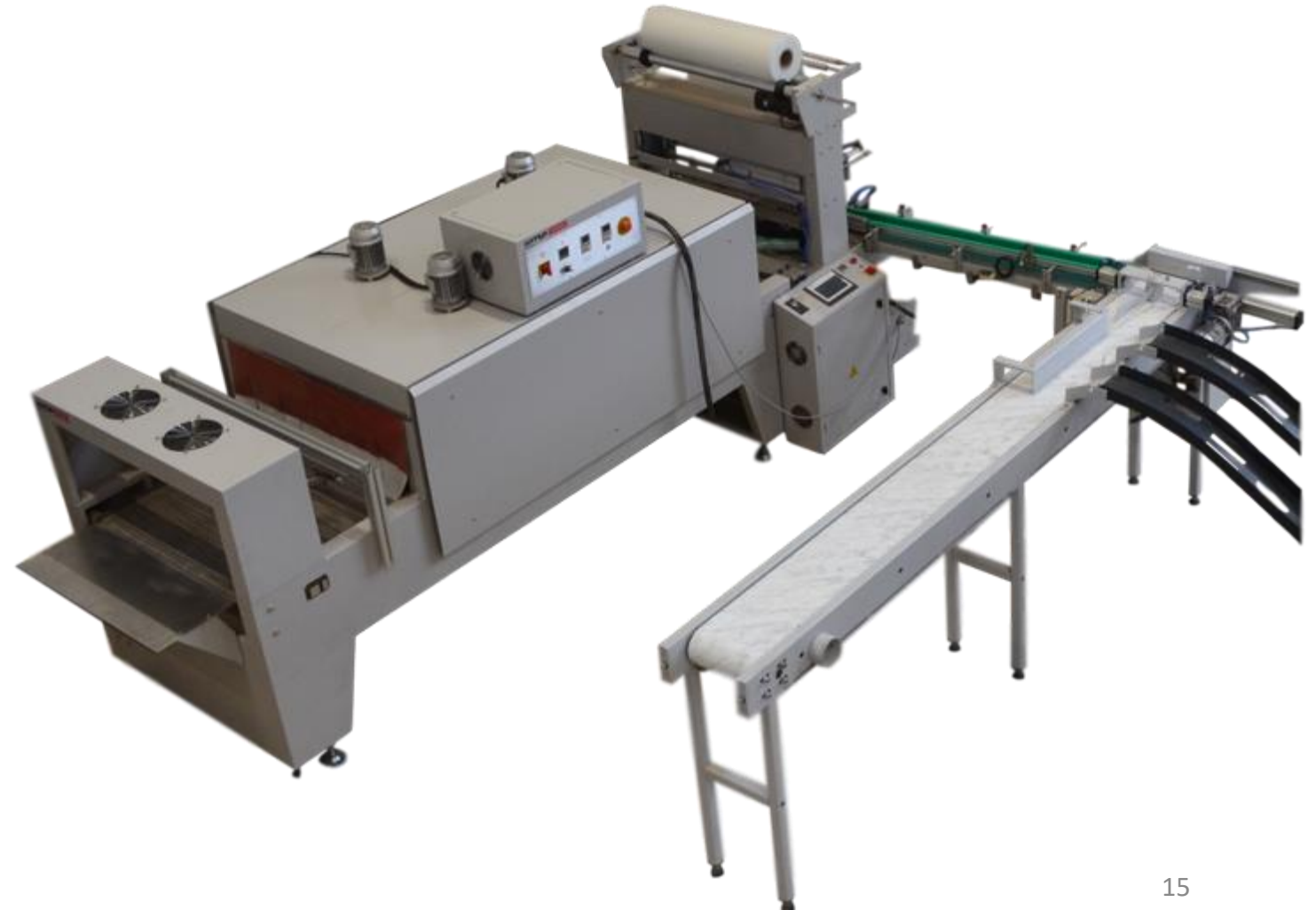

# Benefits of **Automated packing**

## Hand-packed vs Automated



Return on investment of 18 months\*

Reduces dependability on manual labour

Provides retail-ready pack quality which:

- Tightens packs and retains briquette integrity
- Protects from humidity
- Increases visual appeal
- Increases carrying comfort
- Improves stacking rigidity

# FURNITURE PART ASSEMBLY MACHINE

---



Ordered by UAB “Universalūs medžio produktai” to automate the assembly process in compliance to IKEA quality control.

## Project results:

- Lowered production time
- Reduced consumption of gluing solution
- Reduced strain on workers

# FLEXIBLE CONVEYING SOLUTIONS TO FIT CLIENTS NEEDS

UMP **Technika** is highly flexible when it comes to customers surroundings

Various, some unconventional, conveying solutions have been implemented through the years to fit the needs of clients

Expertise in screw, chain, vacuum and belt conveyors have solved numerous business cases

Designed and made in-house.



# HORSE MANURE BRIQUETTING FACILITY FOR A CLIENT IN USA

---



[https://www.youtube.com/watch?v=ZIX1tCCBR7s&feature=emb\\_logo](https://www.youtube.com/watch?v=ZIX1tCCBR7s&feature=emb_logo)

# FULL BRIQUETTE PRODUCTION LINE FOR UAB "VAKARŲ BERŽAS"

**AUTOMATED SAWDUST STORAGE,  
TRANSPORT AND DRYING FACILITY**

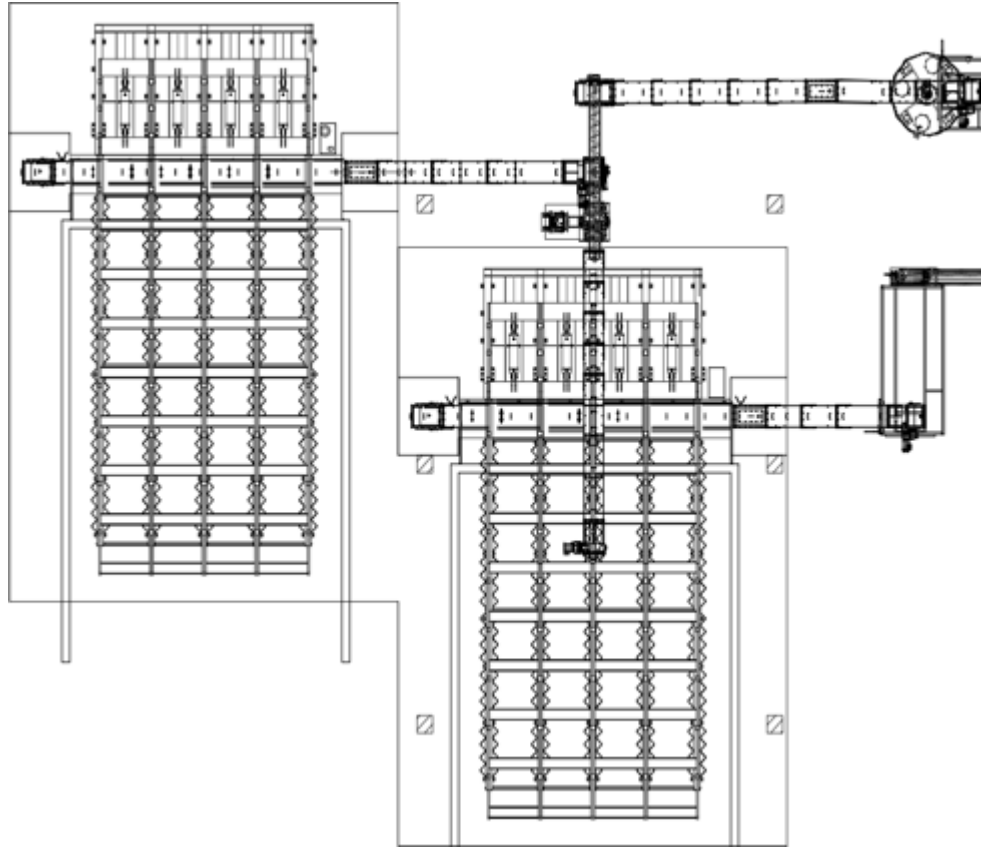

**AUTOMATED BRIQUETTE PACKING AND  
PALLETIZING SYSTEM**

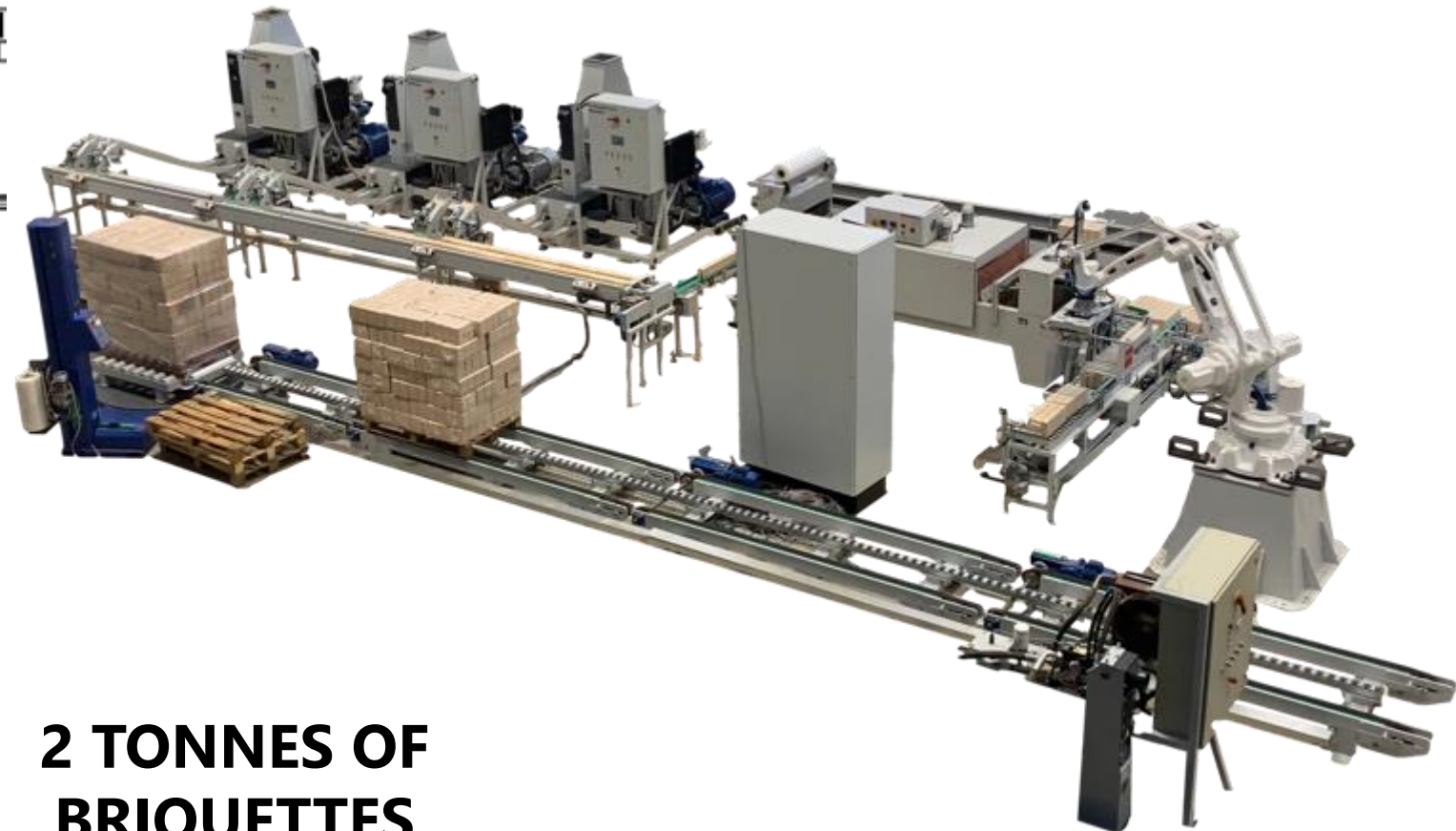

**2 TONNES OF  
BRIQUETTES  
EVERY HOUR,  
24/7**

<https://youtu.be/i7C6TP1dlt8>

# METALWORKING CAPABILITIES

---



- **CUTTING** large pieces of metal up to 350mm in width
- **SURFACE GRINDING** of parts up to 1500x500mm
- **MILLING:**
  - Universal horizontal **MILLING** up to 700x500mm
  - Universal vertical **MILLING** up to 1500x500mm
- **LATHES** supporting parts up to 400x3000mm
- **BORING** machinery capable of creating holes up to 1000x400mm
- **CNC STATION** (magazine holding up to 24 tools) capable of milling parts up to 1500x600mm
- **TIG, MIG/MAG, MMA WELDING** of both small, and large parts

## Metalworking equipment investments planned for 2021:

- **CNC programmable LATHE**
- **LASER CUTTING** and **BENDING**

# OTHER SERVICES OFFERED

---



- **3D PROTOTYPE PRINTING** using **PLA, PETG, ASA, ABS, PC** materials (250x220x220mm)
- **LIQUID PAINTING** using a specialised painting booth (3x6.5x3.8m)
- **ASSEMBLY** of machinery
- **AUTOMATION** of machinery including robotics integration and programming
- Manufacturing of custom **HYDRAULIC CYLINDERS** and other hydraulic parts
- **SERVICE & REPAIR** of hydraulic pumps
- **3000m<sup>2</sup>** of working manufacturing space
- Multiple cranes capable of **5T** load across the full factory space

